



## USER MANUAL

# SMARTWASH+

AUTOMATIC CARPET CLEANER

Refurbished FH52000G Manual

**IMPORTANT:** Read carefully before assembly and use.



# Welcome to Hoover ownership.

Make it official.

---

Register your carpet cleaner by:



Visiting [refurbproductssupport.com](https://refurbproductssupport.com)

---

# Table of Contents

Safety Instructions .....	4
Carton Contents .....	6
Product Guide .....	7
Tools and Accessories.....	8
Before You Begin Cleaning .....	9
Getting Started .....	10
How to Assemble Your SmartWash™ Carpet Cleaner .....	10
Using your SmartWash™ Carpet Cleaner .....	11
Maintenance .....	13
Hoover® Professional Series Solution Guide .....	20
Troubleshooting .....	21
Warranty .....	23
French.....	25
Spanish.....	49

# IMPORTANT SAFETY INSTRUCTIONS SAVE THESE INSTRUCTIONS

When using an electrical appliance, basic precautions should always be followed, including the following:

**READ ALL INSTRUCTIONS BEFORE USING THIS APPLIANCE.**

## **WARNING:**

**TO REDUCE THE RISK OF FIRE, ELECTRIC SHOCK, DAMAGE OR INJURY:**

- Fully assemble before operating.
- Operate vacuum only at voltage specified on data label on back of vacuum canister.
- Do not leave appliance when plugged in. Unplug from outlet when not in use and before cleaning or servicing.
- Do not use outdoors.
- Do not immerse. Use only on carpet moistened by cleaning process.
- To Reduce the Risk of Fire and Electric Shock due to internal component damage, use only HOOVER cleaning fluid intended for use with this appliance. See the Cleaning Fluid section (pg 20) of this manual.
- Do not allow to be used as a toy. Not intended for use by children age 12 and under. Close supervision is necessary when used near children. To avoid injury or damage, keep children away from product, and do not allow children to place fingers or other objects into any openings.

- Use only as described in this manual. Use only manufacturer's recommended attachments and products.
- Do not use with damaged cord or plug. If appliance is not working as it should, has been dropped, damaged, left outdoors, or dropped into water, take it to a service center prior to continuing use.
- Do not pull or carry by cord, use cord as a handle, close a door on cord, or pull cord around sharp edges or corners. Do not place product on cord. Do not run appliance over cord. Keep cord away from heated surfaces.
- Do not unplug by pulling on cord. To unplug, grasp the plug, not the cord.
- Do not handle plug or appliance with wet hands.
- Do not put any object into openings. Do not use with any opening blocked; keep free of dust, lint, hair and anything that may reduce air flow.
- Keep hair, loose clothing, fingers, and all parts of body away from openings and moving parts.
- Turn off all controls before unplugging.
- Use extra care when cleaning on stairs. To avoid personal injury or damage and to prevent the cleaner from falling, always place cleaner at bottom of stairs or

on floor. Do not place cleaner on stairs or furniture, as it may result in injury or damage.

- Do not use to pick up flammable or combustible liquids, such as gasoline, or fine wood sandings, or use in areas where they may be present.
- Connect to a properly grounded outlet only. See Grounding Instructions.
- Do not pick up anything that is burning or smoking, such as cigarettes, matches, or hot ashes.
- Do not use without filters and tanks in place.
- Do not clean over floor electrical outlets.

**WARNING:** This product contains chemicals known to the State of California to cause cancer, birth defects or reproductive harm. **WASH HANDS AFTER HANDLING.**

## GROUNDING INSTRUCTIONS:

This appliance must be grounded. If it should malfunction or breakdown, grounding provides a path of least resistance for electric current to reduce the risk of electric shock. This appliance is equipped with a cord having an equipment-grounding conductor (C) and grounding plug (A). The plug must be inserted into an appropriate outlet (B) that is properly installed and grounded in accordance with all local codes and ordinances.

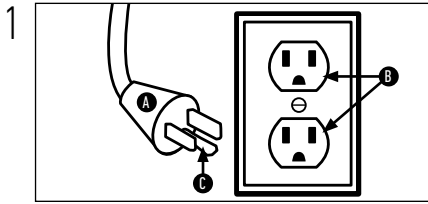

## WARNING:

Improper connection of the equipment-grounding conductor can result in the risk of electric shock. Check with a qualified electrician or service person if you are in doubt as to whether the outlet is properly grounded. Do not modify the plug provided with the appliance - if it will not fit the outlet, have a proper outlet installed by a qualified electrician. This appliance is for use on a

nominal 120-volt circuit and has a grounding plug that looks like the plug (A) illustrated in Fig. 1. A temporary adapter (D) may be used to connect this plug to a 2-pole receptacle (E) if a properly grounded outlet is not available (Fig. 2). The temporary adapter should be used only until a properly grounded outlet (B) can be installed by a qualified electrician (Fig. 1). The green colored rigid ear, lug, or the like (F) extending from the adapter must be connected to a permanent ground (G) such as a properly grounded outlet box cover (Fig. 2). Whenever the adapter is used, it must be held in place by a metal screw. **NOTE:** In Canada, the use of a temporary adapter is not permitted by the Canadian Electrical Code.

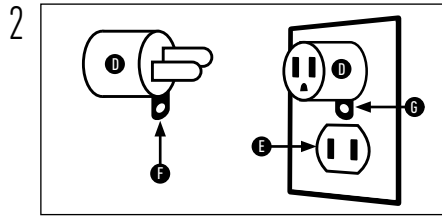





## CAUTION:

### TO REDUCE THE RISK OF DAMAGE:

- Avoid picking up hard, sharp objects with this product, as they may cause damage.

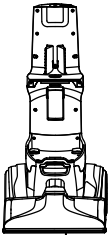
- Store appropriately indoors in a dry place. Do not expose machine to freezing temperatures.
- Do not use sharp objects to clean out hose as they can cause damage.
- To assist in reducing drying time, be certain the area is well ventilated when using detergents and other cleaners with this machine.
- To help prevent matting and resoiling, avoid contact with carpets until they are dry. Keep children and pets away from carpets until they are completely dry.
- Do not store extractor with solution in tanks.
- With brushes and brush roll on, do not allow cleaner to sit in one location for an extended period of time, as damage to the floor can result.
- Do not use this extractor on hard floors. Using this machine on hard floors may scratch or damage your floor.
- Water will drip from the brushes and underside of the product after use and may puddle. To avoid damage to wood and laminate flooring and to avoid potential slip hazard, after use (a) do not leave the product on wood and laminate surfaces and remove to a hard surface and (b) place unit on absorbent material (such as a towel) to soak up drips.

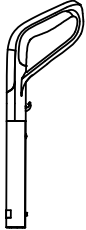
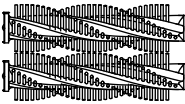
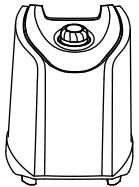
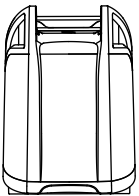
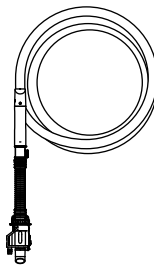
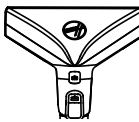
# What's in the Box?

Carpet Cleaner		Solution Tank		Upper Handle		FlexForce™ PowerBrushes	
Water Tank			Accessory Hose			2-in-1 Antimicrobial Tool*	
						Mesh Tool Storage Bag	
						Sample Bottle of Cleaning Solution	

\*Tools and Accessories vary per model. Accessories not included with your model may be purchased separately by visiting [Hoover.com](http://Hoover.com)

# Getting to Know Your Hoover® SmartWash™

1. Triggerless Handle Design
2. Clean Water Tank
3. Filter
4. Dirty Water/Recovery Tank
5. Hose Connection
6. Removable Recovery Nozzle
7. Automatic Wash/  
Dry LED Display
8. Removable FlexDuo™ PowerBrushes
9. Solution Tank
10. Carry Handle
11. Cord Wrap
12. Handle release Pedal
13. On/Off Pedal

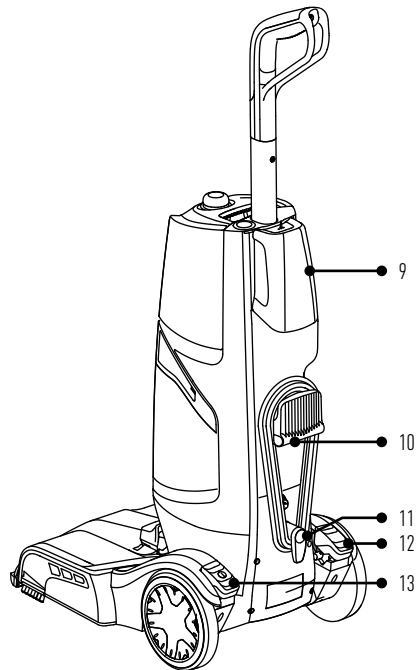
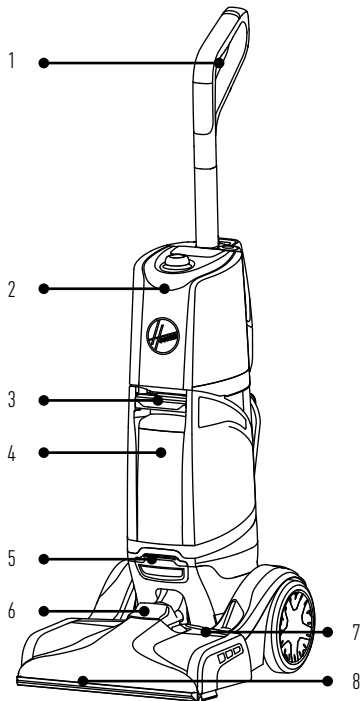

## Tools & Accessories:

Stair Tool\*

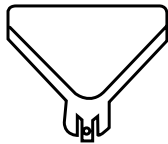

Crevice Tool\*



Upholstery Tool\*

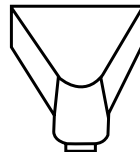

### 2-in-1 Antimicrobial Tool\*:

Antimicrobial tool that helps prevent bacteria growth and odors allows you to choose between two inserts.

A. The rubber nub insert is for unpleasant stain removal and hygienic clean ups

B. The bristle insert is for tough scrubbing power

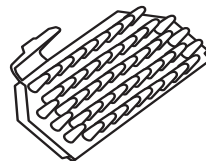
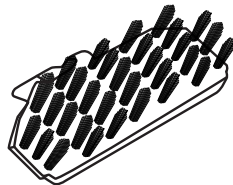
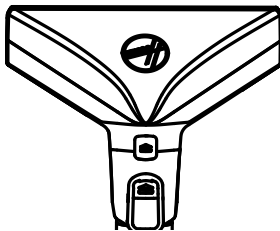



## Before You Begin Cleaning:

Vacuum carpet and upholstery thoroughly with a Hoover vacuum before use.

Don't use the carpet cleaner as a traditional vacuum cleaner.

Use your Hoover carpet cleaner only if upholstery fabric is marked with a "W" (for "wet" clean) or "S/W" (for "solvent/dry" or "wet" clean). Don't clean fabric marked "S" ("solvent/dry" clean only).

Test for colorfastness in a small, hidden area. Gently rub surface with a dampened white cloth. Wait ten minutes and check for color removal or bleed with a white paper towel.

Move furniture out of area to be cleaned. Place aluminum foil or wax paper under legs of furniture too heavy to move to prevent wood finishes from staining carpet. Pin up furniture skirts and draperies.

Pretreat spots and heavy traffic areas with a Hoover® Cleaning Solution\*. See the "Cleaning Solutions" section.

\*Available at additional cost if not included with your model.

## Pretreating:

For best results, pretreat stains with a Hoover spot treatment (see Hoover Cleaning Solution Guide, pg. 18) to help loosen and remove even the most stubborn stains.

**NOTE:** To prevent staining, use plastic or aluminum foil to protect wood or metal surfaces from possible water spray.

**NOTE:** To avoid damage to wood floors underneath area rugs or carpet, place waterproof material (ex: plastic) underneath them before cleaning.

### CAUTION

Do not clean over floor electrical outlets. Water will drip from the brushes and underside of the product after use and may puddle. To avoid damage to wood and laminate flooring and to avoid potential slip hazard, after use (a) do not leave the product on wood and laminate surfaces and move to a hard surface and (b) place unit on an absorbent material (such as a towel) to soak up drips.

### IMPORTANT

For full suction, it is important that the Dirty Water Tank is properly secured before cleaning.

Continue using dry strokes until little water is visible passing through the nozzle.

For best results, Hoover recommends rinsing carpet with water only. This removes residual carpet cleaning solution. Remove Solution Tank and repeat. For heavily soiled areas, repeat. Avoid saturating carpet.

**NOTE:** Empty Dirty Water Tank when the motor sound becomes higher pitched and there is a loss in suction (see "Automatic shut-off"). You will also see the float rise and shut off suction at the same time.

# Getting Started With Your SmartWash™ Carpet Cleaner:

## Assembly

- 1 Insert the handle into the base until you hear a "click".

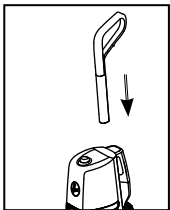

- 2 Wrap the power cord around the cord hooks for convenient storage.

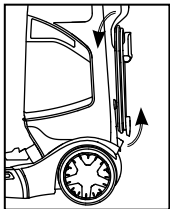

## Fill the Clean Water Tank

- 1 Lift up to remove the Clean Water Tank.

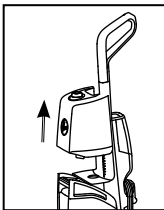

- 2 Remove the cap and add warm water to the top of tank. Replace cap.

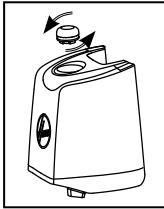

- 3 Align Clean Water Tank with the body of the unit and press FIRMLY into place.

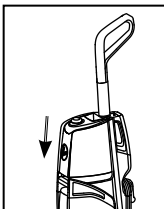

## Fill the Solution Tank

- 1 Remove the Solution Tank from the back of the unit.

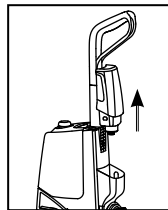

- 2 Remove the cap and fill with Hoover® Cleaning Solution to the top of the tank. Replace cap.

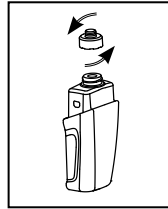

- 3 Place the Solution Tank back into the unit and press FIRMLY into place.

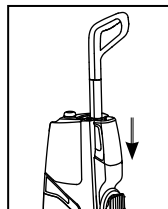

# Using Your SmartWash™ Carpet Cleaner

- 1 Unwrap the power cord and plug unit in an electrical outlet.

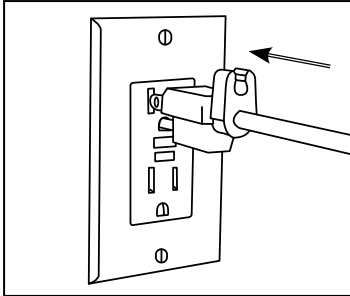

- 2 Step on the Handle Release Pedal to recline the unit for cleaning position.

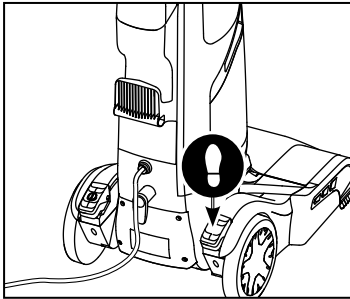

- 3 Step on the Power Pedal to turn ON.

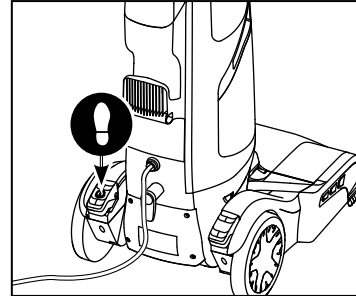

# Using Your SmartWash™ Carpet Cleaner

- 4 Slowly move forward. The unit will automatically dispense the optimal amount of water and cleaning solution.

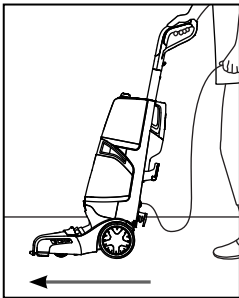

- 5 Slowly pull backward. The unit will automatically dry your carpets by extracting the water.

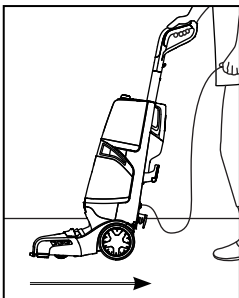

- 6 When your cleaning is complete and you want to reduce the dry time, press the Dry Only button. The Dry Only mode will extract remaining water from your carpet. Continue in this mode until little water is visibly passing through the nozzle.

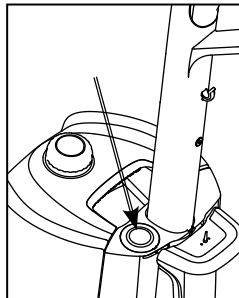

- 7 For best results, Hoover recommends rinsing the carpet with clean water only. This will remove residual carpet cleaning solution from your carpets. To Rinse with clean water only, remove the Solution Tank and then repeat steps 4 through 6.

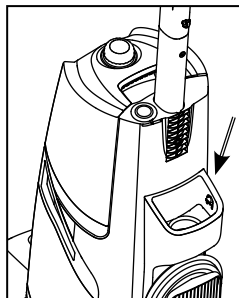

# Maintenance

## How to Empty

- 1 Turn the cleaner off and unplug from electrical outlet.

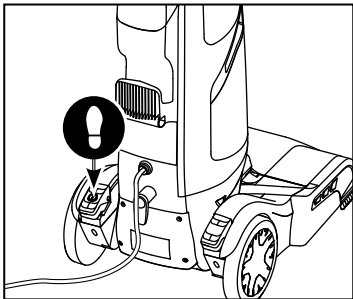

- 2 Grab the Dirty Water Tank handle and pull up to release. Remove Tank from carpet cleaner base at an angle.

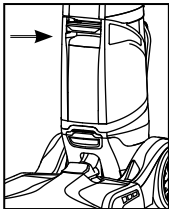

- 3 Place on a flat surface and unlatch Dirty Water Tank lid to remove top of tank.

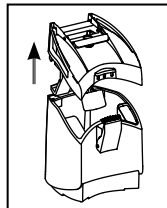

- 4 Empty tank, rinse, wipe filter clean and allow to air dry.

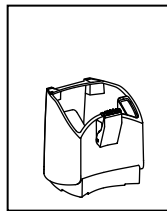

**Dirty Water Tank:** Your carpet cleaner is equipped with a shut off float within your dirty water tank. When the dirty water tank becomes full, the float will rise, shutting off the air flow through the nozzle. Once the float is activated, empty the dirty water tank.

# Notices

## **IMPORTANT**

Regarding the Dirty Water Tank: For full suction it is important that the Dirty Water Tank Lid is securely in place. If misplaced, poor to no suction will result.

## **IMPORTANT**

For full suction, it is important that the Dirty Water Tank is properly secured before cleaning.

Continue using dry strokes until little water is visible passing through the nozzle.

For best results, Hoover recommends rinsing carpet with water only. This removes residual carpet cleaning solution. Remove Solution Tank and repeat. For heavily soiled areas, repeat. Avoid saturating carpet.

**NOTE:** Empty Dirty Water Tank when the motor sound becomes higher pitched and there is a loss in suction (see “Automatic shut-off”). You will also see the float rise and shut off suction at the same time.

## **CAUTION**

Do not clean over floor electrical outlets. Water will drip from the brushes and underside of the product after use and may puddle. To avoid damage to wood and laminate flooring and to avoid potential slip hazard, after use (a) do not leave the product on wood and laminate surfaces and move to a hard surface and (b) place unit on an absorbent material (such as a towel) to soak up drips.

# Maintenance

## How to Remove and Clean Nozzle

- 1 To prevent possible leaking, remove and empty Clean Water Tank, Dirty Water Tank and Solution Tank.

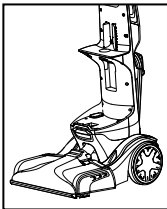

- 2 With handle in upright position, lift up on the Nozzle release then pull Nozzle forward to remove from carpet cleaner. BE CAREFUL not to instantly pull nozzle straight up.

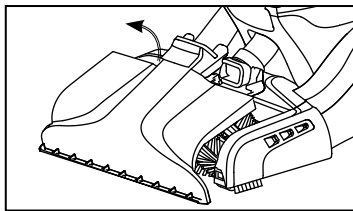

- 3 Rinse debris from Nozzle.

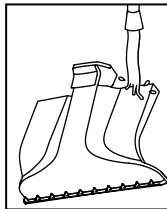

- 4 Position Nozzle onto foot, making sure to align the tabs at the top of the Nozzle with the notches inside the foot.

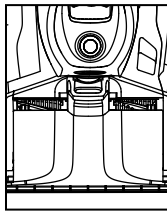

- 5 Slide Nozzle forward to snap into position.

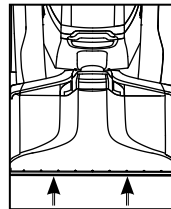

To reduce the risk of injury from moving parts, unplug before servicing.



The nozzle must be in the proper position for the unit to have proper suction.

# Maintenance

## How to Change and Clean Brushes

### HOW TO REMOVE

- 1 To prevent possible leaking, remove Clean Water Tank, Dirty Water Tank and Solution Tank.

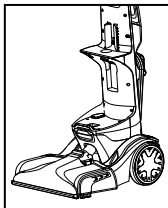

- 2 With handle in upright position, follow "Nozzle: How to Remove and Clean" instructions.

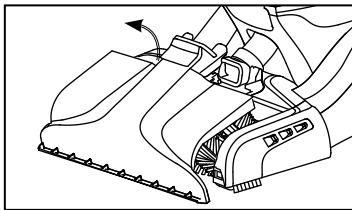

### STORAGE

Before storing: Empty Clean Water Tank and let air dry. Replace on cleaner. Empty Dirty Water Tank, rinse tank and lid thoroughly with clean water and let air dry. Empty Solution Tank, rinse tank with clean water.

Allow brushes and underside of carpet cleaner to air dry thoroughly before storing carpet cleaner on a carpeted or wood surface.

- 3 Grab Side A and pull up to remove. Repeat on the other brush.

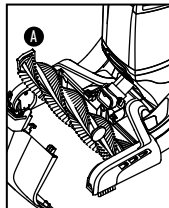

- 4 The brushes can be cleaned under running water.

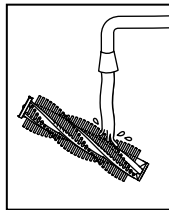

### LUBRICATION

The motor is equipped with bearings that contain sufficient lubrication for the life of the motor. The addition of lubricant could cause damage. Therefore, do not add lubricant to motor bearings or brushrolls.

### HOW TO REPLACE

- 1 At an angle, align side B on the brush to the drive gear.

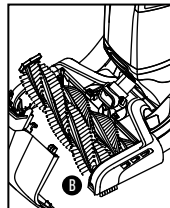

- 2 Press Tab A down until brush snaps in place.

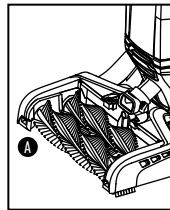

### ! CAUTION !

To reduce the risk of injury from moving parts, unplug before servicing.



# Tools and Accessories

## HOW TO ATTACH HOSE

- 1 Open Hose Connection Port. Insert hose end by inserting **FIRMLY** into Hose Solution Port

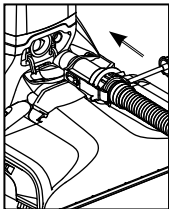

## HOW TO REMOVE HOSE

- 1 Press trigger on tool to ensure all fluid has discharged from the hose. Press button on end of hose and pull to remove hose and solution connection from unit.
- 2 Close the Hose Port Door back into place. Make sure to close door to ensure proper suction. Unit may lose suction if not closed properly.

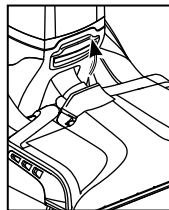
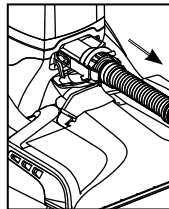

Read "Before You Begin Cleaning" instructions. Be sure to check Hoover Cleaning Guide on page 20 and the cleaning code on your upholstery. Use your cleaner only on upholstery marked "W" or "W/S".



To reduce the risk of injury from moving parts, unplug before servicing.

# Tools and Accessories

## How to Attach Tools

- 1 To ensure maximum performance and to protect your carpet, be sure to place the handle in the upright position while using the hose. Placing the handle in the upright position shuts off the FlexForce™ PowerBrushes.

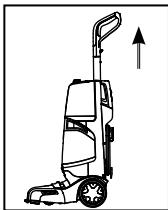

- 2 Connect tool to hose by sliding it onto the connector until it securely locks into place.

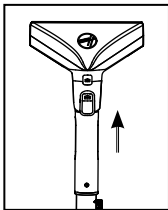

- 3 Using your thumb, push forward and up on the latch to remove tool.

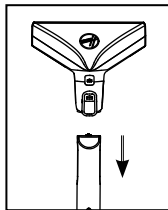

**NOTE:** Do not place unit at top of stairway to avoid falling down stairs.  
Place unit at bottom of stairs and work up.

# Tools and Accessories

## Cleaning Carpeted Stairs and Upholstery

- 1 Read "Before you Begin Cleaning" instruction on page 9.
- 2 Attached hose as instructed (page 18).
- 3 Place handle in upright position. FlexForce™ PowerBrushes will not rotate while handle is in upright position.
- 4 Fill Clean Water Tank according to instructions.
- 5 Fill Solution Tank with Hoover® solution according to instructions.
- 6 Attach tool to end of hose.
- 7 Dry hands and plug cleaner into a properly grounded outlet.
- 8 Turn cleaner ON.
- 9 Pre-spray the area by holding the tool about one inch above the carpet and push it forward while pressing the trigger.
- 10 Slightly press the tool into area cleaning. Press the trigger and pull the tool slowly over the carpet. Release trigger at end of stroke.
- 11 Lift tool, and position it against Nozzle. Pull tool slowly over carpet without pressing trigger.
- 12 Overlap strokes by ½ inch to help prevent streaking.
- 13 It is best to alternate wet and dry strokes as described in steps.

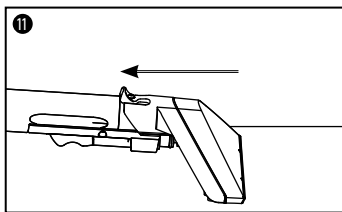
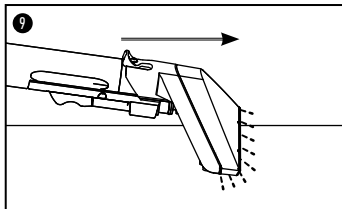

## Tips

To avoid saturating carpet, do not use more than 4 wet strokes over any one area. Always end with dry strokes.

If additional cleaning is necessary, wait until the carpet is completely dry before using the tool again.

Empty Dirty Water Tank when the motor sound becomes higher pitched and there is a loss of suction. You will also see the float rise and shut off suction at the same time.

When finished cleaning, follow "after Cleaning" and "After Using Tool" instructions.

### ⚠ CAUTION ⚠

Use extra care when cleaning on stairs. To avoid personal injury or damage, and to prevent the cleaner from falling, always place cleaner at the bottom of stairs or on floor. Do not place cleaner on stairs or furniture, as it may result in injury or damage.

# Hoover® Cleaning Solution Guide

Use only Hoover cleaning solutions to prevent potential harm to your carpet cleaner and keep your warranty.

For best results, use your Carpet Cleaner + Spot Treatment + Solutions.

Hoover has a full line of Detergents and Spot Treatments to complement your Hoover carpet cleaner and the specific condition of your carpet. To prevent project interruption, keep Detergent on hand and store with your carpet cleaner. Spot Treatment may be used as a pretreatment immediately before you clean your carpets, or as an independent treatment between cleaning your carpets.

## EXPERT CARPET SOLUTIONS: PROFESSIONAL GRADE



### EXPERT CLEAN™ CARPET WASHER DETERGENT

Powerful, professional strength cleaner lifts dirt and removes allergens for our deepest, extreme clean.



### EXPERT CLEAN™ SPOT TREATMENT GEL

Professional grade targeted gel removes tough stains like ground-in dirt, allergens, chocolate and wine.



### EXPERT PET™ CARPET WASHER DETERGENT

Powerful, professional strength enzymes break down biological stains, dirt and odor for a truly deep clean.



### EXPERT PET™ SPOT TREATMENT SPRAY

Professional grade targeted enzyme spray removes tough stains like dirt, oils, urine and residual odor.

## PLUS CARPET SOLUTIONS



### **CLEAN PLUS™ CARPET WASHER DETERGENT**

Powerful cleaner for everyday dirt and grime.



### **CLEAN PLUS™ SPOT SPRAY**

Powerful spot spray for everyday dirt and grime.



### **PET PLUS™ CARPET WASHER DETERGENT**

Powerful cleaner enhanced with enzymes to tackle pet messes and eliminate odor.



### **PET PLUS™ SPOT SPRAY**

Powerful spot spray enhanced with enzymes to tackle pet messes and eliminate odor.



### **PRO PLUS™ CARPET WASHER DETERGENT**

Professional strength carpet & upholstery solution removes stubborn stains and odors.

## HARD FLOOR SOLUTIONS



### **MULTI-FLOOR PLUS™ HARD FLOOR SOLUTION**

Powerful hard floor cleaning solution removes everyday dirt and grime.



### **TILE & GROUT PLUS™ HARD FLOOR SOLUTION**

Powerful hard floor cleaning solution cleans and revitalizes tile and grout surfaces.



### **STEAM PLUS™ HARD FLOOR SOLUTION**

Powerful hard floor cleaning solution combines with steam to safely wash hard floors.

## Need Help?

If you need further assistance, please contact Refurb Product Support via the website at [www.RefurbProductSupport.com](http://www.RefurbProductSupport.com). Support agents are available Monday through Friday from 8am to 4pm EST. Always identify your vacuum by the complete model number when requesting information. The model number appears on the bottom of the vacuum.

### Troubleshooting:

Any other servicing should be done by an authorized service representative.

USE TROUBLESHOOTING GUIDE AS A FIRST STEP TO RESOLVE ANY PROBLEMS YOU MAY BE EXPERIENCING.

If appliance is not working as it should, has been dropped, damaged, left outdoors, or dropped into water, contact [refurbproductsupport.com](http://refurbproductsupport.com) for further instruction before continuing use.

### QUESTIONS OR CONCERNS?

*If you have any questions, visit [refurbproductsupport.com](http://refurbproductsupport.com). Do not return to store. See back of product for model number.*

#### **WARNING**

To reduce the risk of personal injury - Unplug before cleaning or servicing.

#### **WARNING**

To reduce risk of fire and electric shock due to internal component damage, use only Hoover cleaning products intended for use with the appliance as noted.

<b>PROBLEM</b>	<b>POSSIBLE CAUSE</b>	<b>POSSIBLE SOLUTION</b>
<b>Cleaner won't run</b>	<ol style="list-style-type: none"> <li>1. Not firmly plugged in</li> <li>2. No voltage in wall plug</li> <li>3. Blown fuse or tripped breaker</li> <li>4. Fuse in cleaner blown</li> <li>5. On/Off pedal not depressed</li> </ol>	<ol style="list-style-type: none"> <li>1. Plug unit in firmly.</li> <li>2. Check fuse or breaker in home.</li> <li>3. Replace fuse or reset breaker in home.</li> <li>4. Take to service center.</li> <li>5. Press pedal.</li> </ol>
<b>Low suction</b>	<ol style="list-style-type: none"> <li>1. Dirty Water Tank full/automatic shut off engaged</li> <li>2. Blockage in tool on end of hose</li> <li>3. Dirty Water Lid not on correctly</li> <li>4. Dirty Water Tank Debris Filter clogged</li> <li>5. Blockage in nozzle</li> <li>6. Recovery Tank not properly secured</li> <li>7. Recovery Nozzle not on correctly</li> <li>8. Blockage in hose</li> </ol>	<ol style="list-style-type: none"> <li>1. Remove and empty Dirty Water Tank. See "How to Empty" page 13.</li> <li>2. Remove tool and clear blockage.</li> <li>3. Make sure lid is on securely. See "How to Clean" page 13.</li> <li>4. See "How to Clean" page 13.</li> <li>5. See "How to Clean" page 15.</li> <li>6. Replace Recovery Tank and secure recovery tank latch.</li> <li>7. Remove and replace Recovery Nozzle. See "How to Clean &amp; Remove Nozzle" page 15.</li> <li>8. Drop a coin through, clear with broom handle.</li> </ol>
<b>Hose Nozzle stops spraying liquid during use</b>	<ol style="list-style-type: none"> <li>1. Clean Water Tank or Detergent Container is empty</li> <li>2. Loose connection to solution port on foot of cleaner</li> </ol>	<ol style="list-style-type: none"> <li>1. Turn off Cleaner and fill Clean Water tank &amp; Detergent Container.</li> <li>2. Check for secure connection to solution port on foot of Cleaner.</li> </ol>
<b>Accessory Tool will not spray after filling the Clean Water Tank or Solution Tank</b>	<ol style="list-style-type: none"> <li>1. Air is trapped in the hose &amp; pump</li> </ol>	<ol style="list-style-type: none"> <li>1. Turn on the Cleaner. If hose does not spray, prime the pump by lowering the hose down to the floor and hold the trigger for up to one minute.</li> <li>2. Aim downward &amp; squeeze trigger.</li> </ol>
<b>Hose will not spray after priming pump</b>	<ol style="list-style-type: none"> <li>1. Pump is defective</li> <li>2. Not connected properly</li> </ol>	<ol style="list-style-type: none"> <li>1. Call for service: 1-800-944-9200.</li> <li>2. Check connection.</li> </ol>
<b>Clean water won't dispense</b>	<ol style="list-style-type: none"> <li>1. Clean Water Tank or Solution Tank not firmly in place</li> <li>2. Clean Water Tank or Solution Tank empty</li> </ol>	<ol style="list-style-type: none"> <li>1. Make sure tank is securely locked in position.</li> <li>2. Refill container according to cleaning instructions.</li> </ol>
<b>Solution won't dispense</b>	<ol style="list-style-type: none"> <li>1. Unit is not moving in forward direction</li> </ol>	<ol style="list-style-type: none"> <li>1. Ensure unit is moving in forward direction.</li> </ol>
<b>Brushes won't rotate during floor cleaning</b>	<ol style="list-style-type: none"> <li>1. Brushroll stall protection activated</li> <li>2. Unit in upright position</li> </ol>	<ol style="list-style-type: none"> <li>1. Turn the unit off and back on, then inspect and clean for jams.</li> <li>2. Brushes will not rotate in upright position. Step on handle release to start cleaning.</li> </ol>
<b>Water is Leaking out of Carpet Cleaner</b>	<ol style="list-style-type: none"> <li>1. Clean Water Tank, Solution Tank or Dirty Water Tank not FIRMLY in place</li> </ol>	<ol style="list-style-type: none"> <li>1. Make sure the tank is secure.</li> </ol>

# SERVICE & WARRANTY

## SERVICE INFORMATION

Remanufactured, refurbished, or reconditioned products have a limited warranty as determined by the retailer selling the product to you. This product is warranted against failure due to a defect in materials or workmanship from the date of original purchase. Proof of the original purchase date is needed to make a warranty request or claim. Consumers are required to register their products by visiting <https://www.refurbproductsupport.com>

This warranty is extended to the original purchaser only for products purchased for home use within the contiguous 48 US states. The warranty is not transferrable.

What your warranty does not cover.

- Product purchased "as-is"; clearance; closeout; directly or indirectly from a liquidation website
- Improper installation; Content losses due to failure of the unit
- Failure of the product if it is abused, misused, or used for other than the intended purpose or used for commercial purposes
- Products with original serial number or ARC license plate number that has been removed, altered, or cannot be readily determined
- Rust on the interior or exterior of the product
- Replacement of house fuses or resetting of circuit breakers
- Damage to the product caused by accident, fire, flood or acts of God
- Incidental or consequential damage to personal property caused by possible defects with this appliance
- Costs for removal, packaging, transportation, shipping and/or installation of the unit repair or replacement
- Cosmetic defects, including any plastic part. Inside components such as door panels, door shelves, racks, light bulbs, etc.
- Batteries of any chemistry

Some states do not allow the exclusion or limitation of incidental or inconsequential damages. This warranty gives you specific legal rights and you may have other rights which vary from state to state. To know what your legal rights are, consult your local or state consumer affairs office or your state's Attorney General.

Exclusion of implied warranty. Except where prohibited or restricted by law, there are no warranties, whether express, oral, or statutory which extend beyond the description of the face hereof, including specifically the implied warranties of merchantability or fitness for a particular purpose.